

- 1** Switch on the unwinder, printer andrewinder.

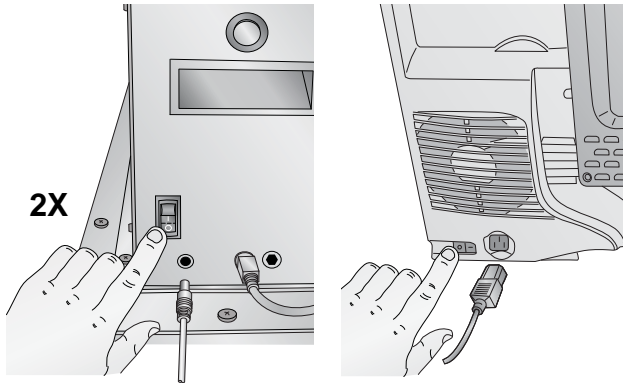

Loading Label Stock Quick Reference Guide

- 2** Place the label stock roll (max 12" OD) on the unwinder chuck. Push the stock all the way back until it touches the stop disc.

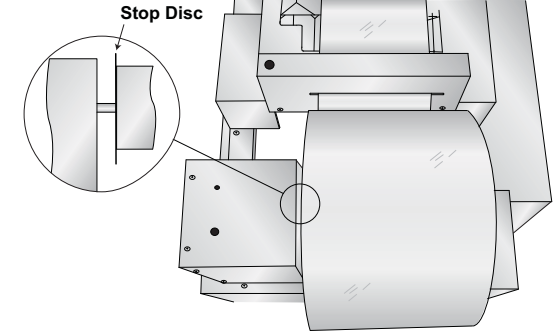

- 3** The loose stock should fall on the right side of the roll. Turn the tension knob clockwise to secure the roll to the chuck. Turn the knob as tight as you can! Feed the stock under the dancer arm and through the cutter.

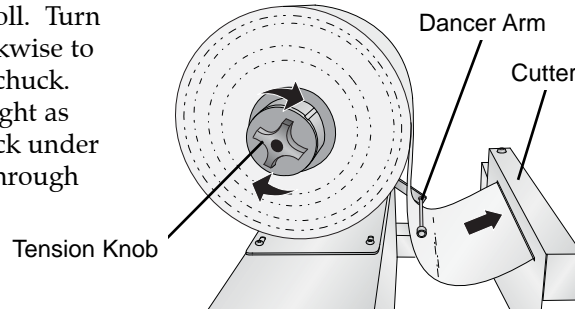

- 4** Continue feeding the stock into the printer feeder tray. Feed the stock under the green guides and under the paper feed roller. Stop feeding when the leading edge of the stock has covered the red stop block printed just outside the feeder door entrance.

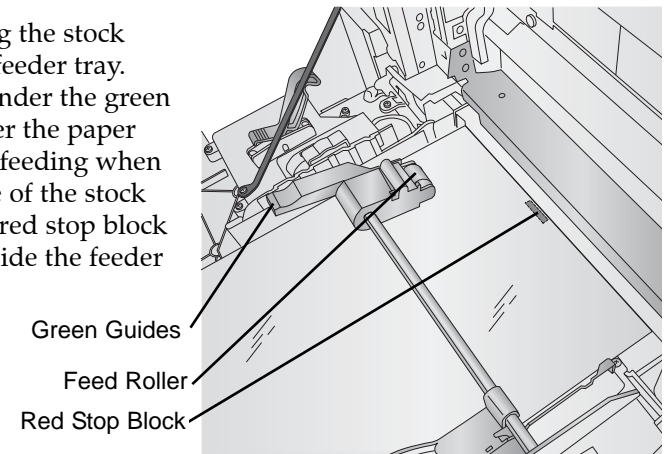

- 5** Place an empty label core on the rewinder chuck. Push the core all the way back until it touches the back label guide disc.

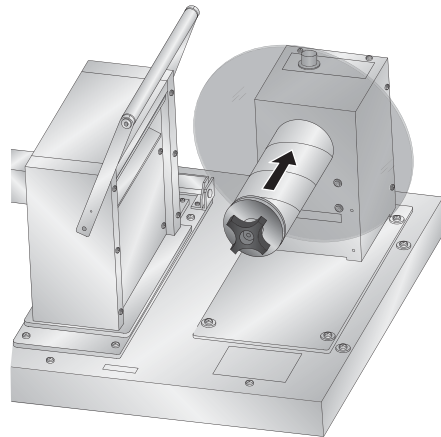

- 6** Place the outer label guide disc on to the rewinder chuck. Push the guide until it touches the rewinder core. Turn the tension knob clockwise to secure the core and the label guide to the chuck.

Note: Some cores may be shorter than the stock width. If so, make sure the distance between the label guide discs is slightly larger than the stock width.

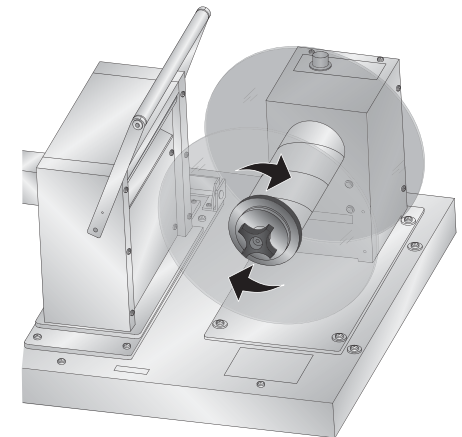

7 Print your label according to Section 5 of the manual.

Note: Depending on when the printer was last used, the fuser will need to heat up or cool down before the printer will print. This can take from 2 seconds to 2 minutes.

8a Attach the label stock to the rewinder core.

As the printer is preparing to print, get a piece of tape ready. It is best to stand to the right side of printer with your arms above the rewinder roll. As the stock is ejected from the printer guide it with your left hand through the tensioner unit. As soon as it clears the tensioner place the tape on the middle of the end of the stock.

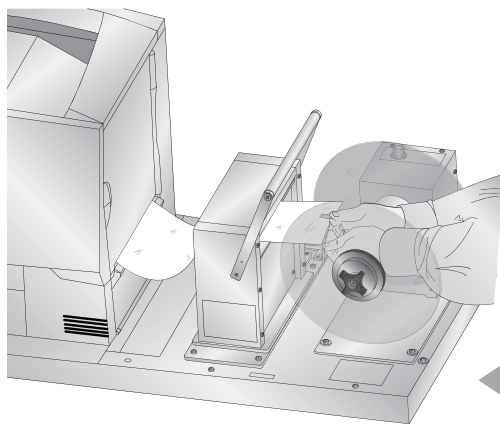

8b The stock will continue to feed at a slower speed. When it reaches the rewinder, attach it to the top of the empty label core. Position the stock so that it that it is centered on the core.

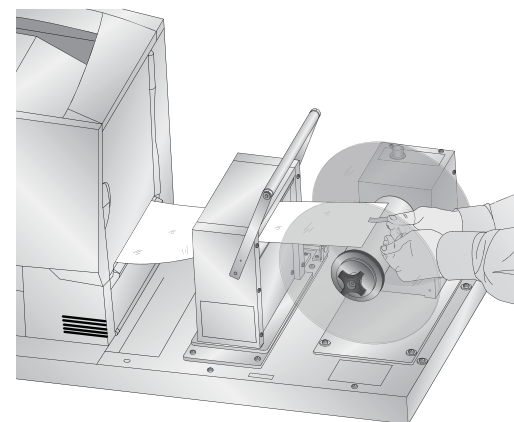

8c Immediately after the label stock is attached, engage the Rewinder by flipping the Rewinder Dancer Arm toward the printer until it touches the paper.

Important! To minimize the slack loop that will be created under the rewinder, it is very important that you engage this arm immediately after the label stock is taped to the core.

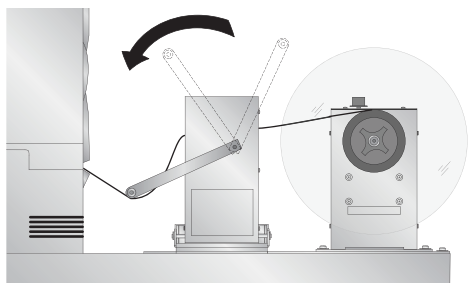

i Important Note: The taping process occurs very quickly so you may not get the label stock attached correctly the first time you try it. It is important to attach the label stock centered on the core. If the attached label stock is too far to the right or left the paper may fold over itself and cause an uneven wrap. If you think the label stock was not attached properly, cancel the print job using the control panel on the front of the printer.

